

ASCD [n.d.]

SOME
"ELSEC" PROTON MAGNETOMETER OWNERS

- Australia Tasmania University
South Australian Mines Department
- Austria Zentralanstalt Fur Meteorologie Und Geodynamik
- Britain Imperial College of Science & Technology,
Geophysics Department
Cambridge University, Dept. of Geodesy & Geophysics
Durham University, Dept. of Geology. (Durham)
Durham University, Dept. of Geology. (Newcastle)
Glasgow University, Dept. of Geology
Geological Survey & Museum, South Kensington
Royal Greenwich Observatory, Herstmonceau
The Crown Agents
- Canada Noranda Exploration Co. Ltd.
Kerr-Addison Gold Mines Ltd.
Ventures Limited
- Falkland Is. The Crown Agents
- Finland Oy Control Ab
- France Compagnie Generale de Geophysique
Office de la Recherche Scientifique et
Technique Outre-Mer
C.N.R.S., Centre d'Etudes Geophysique
Institut de Physique du Globe
Bureau de Recherches Geologiques et Minieres
- Germany Gottingen University, Geophysiques Institut
Schering-Institut
Geophysikalisches Observatorium Furstenfeldbruck
Bundesanstalt Fur Bodenforschung
- Ghana Ghana Geological Survey
The Crown Agents
- India Osmania University, National Geophysical
Research Institute
- Italy Fondazione Ing. C. M. Lerici
- New Zealand Dept. of Scientific & Industrial Research

Some "Elsec" Proton Magnetometer Owners

<u>Saudi Arabia</u>	M.S.A. Baghaffar, (Government Agents)
<u>Somali Land</u>	The Crown Agents
<u>South Africa</u>	Anglo American Corporation of South Africa Ltd. Magnetic Observatory, Hermanus Department of Transport, Cape Town
<u>Sweden</u>	Geological Survey of Sweden
<u>Switzerland</u>	Swiss National Museum, Zurich Geneva University, Institut de Physique Experimental Geneva University, Laboratoire Geophysique
<u>U.S.A.</u>	Hawaii University, Institute of Geophysics Pennsylvania University, Dept. of Physics Wisconsin University, Geophysical & Polar Research Centre Texas University, Dept. of Geology Geo-Recon Inc. Hamilton Standard Archaeological Research Station, Indiana U.S. Navy Hydrographic Office United States Department of the Interior Coast & Geodetic Survey, Washington Carnegie Institution of Washington
<u>Yugoslavia</u>	Rudar Zagreb

[n.d.]

ELSEC

"ELSEC" PROTON MAGNETOMETER PRICE LIST

Magnetometer type 592 as described in leaflets and including detector head, coax cable, leather case, etc.	* £840
Standard spare detector head Type S with slow signal decay	£ 25
Special spare detector head Type F for fast repetition rates	£ 25
30 meter non-microphonic cables fitted with non-magnetic plugs for use on land with Type S or F detector heads	£ 12
Each 100 meters extra cable length	£ 20
Type T detector head for air or ship use, including 100 meters non-microphonic cable	£ 80
Trace recorder control unit type 614A with internal 3" scale span recorder (Rustrak)	£680
Trace recorder control unit type 614B without internal recorder	£580
External 100 mV F.S.D. Potentiometric recorder with 6" scale span for use with type 614A or B units above. Power supply required 230V or 115V 50/60 cycles at 50 VA.	£250
Trace recorder Control Unit type 615, including internal potentiometric recorder	£800
Recommended spares for Magnetometers Type 592	£202

* U.S.A. price - add 10%

May, 1963.

✓ Jan 13th

Manuel 360 Hero

(301) - 762-4858

(301) - 305-7678

INTRODUCING: **SEISMIKTRON**

... a new development in underground surveys ...

ADVANCED SYSTEMS LABORATORIES, INC. recently has developed a new instrument which will:

- * Explore the subsurface of the ground and detect all underground substrata and abnormalities WITHOUT DRILLING.
- * Determine the characteristics of the subsurface (Will identify the type of material).
- * Locate the depth to the subsurface.

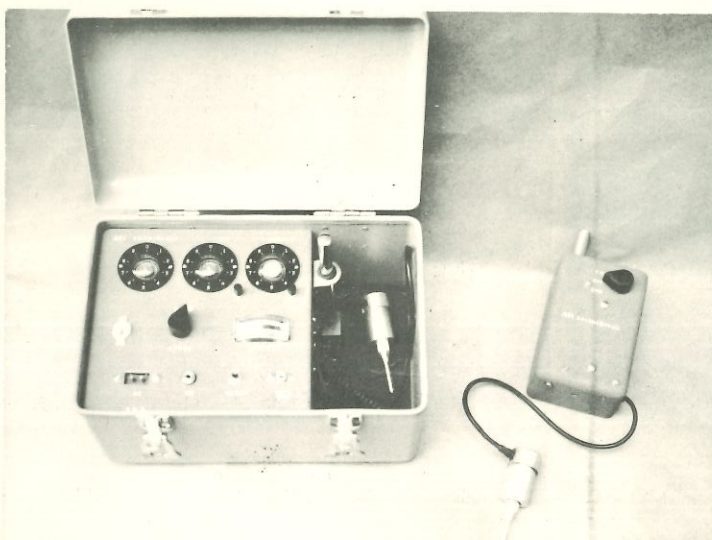

ASL SEISMIKTRON - Instrument consists of the Main Counter Unit and the Transmitter Unit.

... this lightweight, portable Seismic Instrument quickly and easily:

- determines Ground Density, Dip, Rock Rippability
- detects Boulders and Discountinuties
- locates Fault Lines, Gravel Pits, Mineral Deposits, Water Tables, Buried Streambeds, Air Pockects, Etc.

... and does ALL this without the use of explosives. It reduces or completely eliminates Test Core Drilling. However, when drilling is required, the SeismiKtron will:

- * spot best location for drilling
- * measure continuity between test holes

SEISMIKTRON SAVES TIME AND MONEY

- * Results are obtained quickly in the field.
- * Operation is fast.
- * Unit is maintenance free - self contained batteries are rechargeable by built-in charger.
- * No need to use explosives for most shallow surveys.
- * Simple to use. Can be easily used by persons completely unfamiliar with the instrument.
- * Provides information BEFORE commencing the work in order to bid and estimate costs of excavating.
- * Provides information AFTER commencing the work - Because its use is so simple and fast, more tests can be made to efficiently schedule shovels, scrapers, and blasters for higher profits.

SEISMIKTRON HAS MANY USES

- * Developers and Builders use it to quickly determine suitability of terrain for footings and foundations. Instrument also determines the need to blast for basements.
- * Mining Engineers use it to locate mineral deposits.
- * Pipeline Contractors find it an absolute necessity to prepare their Bids.
- * State Highway Departments make long surveys very fast.
- * Roadbuilders find the SeismiKtron a necessary "everyday working tool".
- * Geologists use it to classify unexplored areas.
- * Colleges and Universities use it for Soil Research.
- * Well-diggers use it to locate Water Tables.
- * Excavators use it as the work progresses to plan efficient use of tools and machines. Also used for initial bidding surveys.
- * Consultants use it to cover more territory quickly in order to serve more customers.



Simply, RESET . . .

. . . strike the ground . . .



. . and get the reading :



HOW DOES IT WORK ?

The ASL Seismiktron is essentially an electronic timer which measures the TIME that a shock wave takes to travel from one point on the earth to another.

Two sensitive pick-ups, called "geophones", are placed in the ground a measured distance apart. A shock wave is generated by striking the ground with a mallet. When the shock wave reaches the first pick-up the timer starts, and when the shock wave reaches the second pick-up, or geophone, the timer stops. The time of travel of the shock wave is accurately shown by the indicator tubes of the instrument.

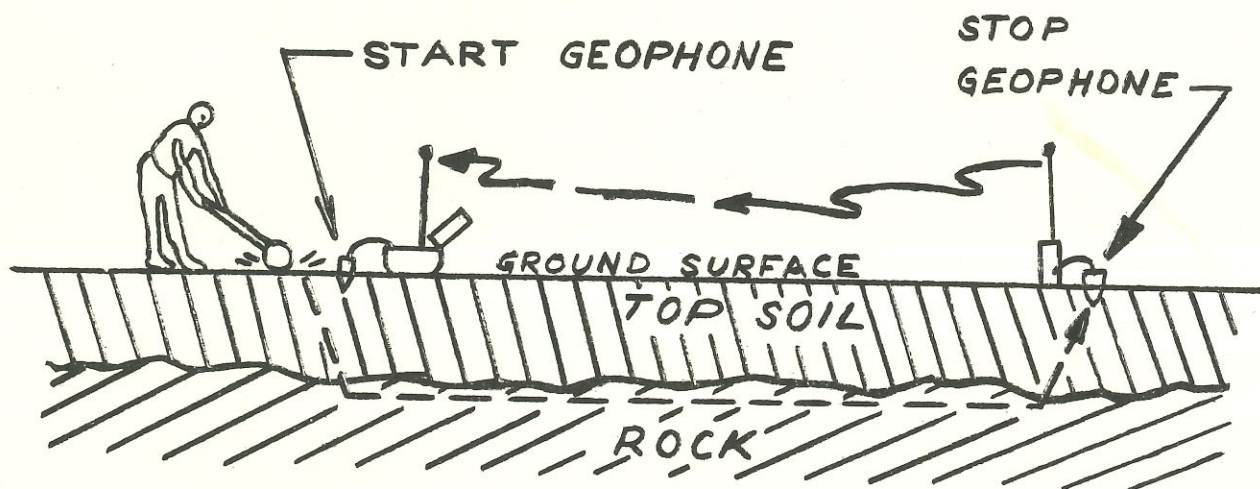

Readings of the time of travel are taken repeatedly as the geophones are placed further and further apart. Since the shock wave travels faster in the harder layers beneath the surface, a point, or separation between the geophones will be found in which the shock wave traveling through the lower layer reaches the stop geophone before the shock wave traveling the direct path on the surface.

The time reading obtained at each location, or separation between geophones, is plotted on a graph. The separation between geophones is increased until we obtain a "break in the curve", or discontinuity in the straight line drawn through the points representing the plot of Time interval versus Distance between geophones. A typical such plot is shown on the next page.

The distance corresponding to the break in the curve is called the "critical distance". Having its value, we can easily find the depth to the rock layer or other underground layer by entering the values obtained from the plot into a nomograph supplied with the instrument.

The number of points, or readings, required will depend on the terrain and on the distances between readings. For most surveys, 10-foot intervals are used. The data from each point are plotted as the survey is made to allow fast results in the field.

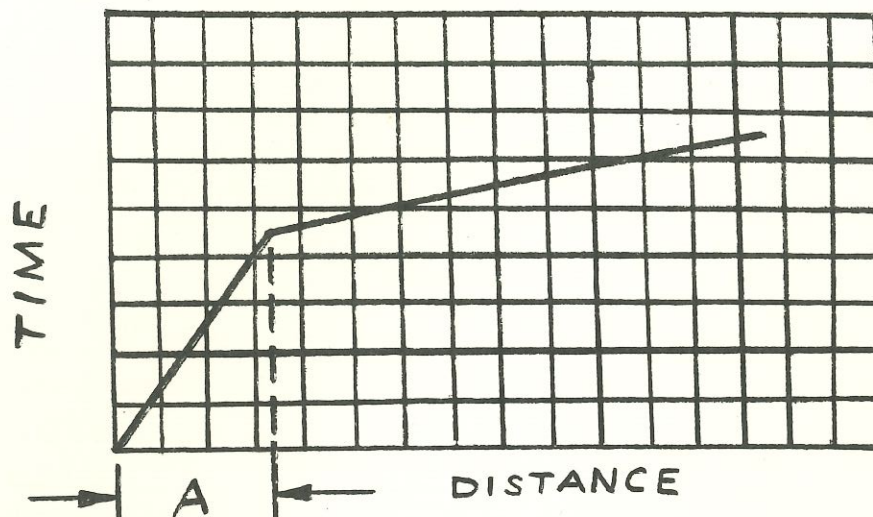

From the slope of the curves the velocity of sound can be computed. Having the value for the speed of sound of a material we can classify the underground material.

DESCRIPTION OF THE SEISMIKTRON

The SeismiKtron consists of two major units. The first of these units is the Main counter Unit. This part of the instrument is permanently housed in the case. The second part is the Transmitter Unit.

The Main Counter Unit consists of the electronic circuits required for the functions of Starting the count of time, for the functions of generating a time reference, and for stopping the action of the time interval counter. There is also a crystal controlled radio receiver and a battery charger circuit.

The Transmitter unit contains a 27 megacycle crystal controlled transmitter, a computer section to control the transmitter, and the circuits associated with the stopping geophone. The Transmitter Unit is the "Heart" of the instrument. The computer section rejects all ground noises

except the particular shock wave generated by the mallet supplied with the instrument. In addition, the computer section continuously samples the background ambient noise in the terrain in order to increase or decrease the sensitivity of the stopping amplifiers. In this manner, the SeismiKtron is able to operate in regions of high ambient noise.

Both the Main Counter Unit and the Transmitter Unit contain rechargeable Nickel-Cadmium batteries. The batteries in the Transmitter Unit are charged from the larger batteries in the Main Unit. The Main Unit has a charger circuit which allows its batteries to be charged from either 115 volts AC, 12 volts DC, or 6 volts DC. The charger circuit will automatically select the polarity, so it does not make any difference what kind of vehicle the user may have. Either positive ground or negative ground systems can be used.

The SeismiKtron provides complete automatic operation. There are no tuning controls for either the receiver or the transmitter. The sensitivity of the stopping amplifier section is continuously adjustable electronically. This allows the instrument to be used by persons having no knowledge of electronics.

The Main Unit has three controls: the ON-OFF switch, the RANGE switch, and the RESET push switch. To operate the instrument it is only necessary to turn it ON, select the Range desired, and push the RESET switch to clear the reading.

When the instrument is Reset it allows the accumulation of time to proceed as soon as the ground is hit near the starting geophone. The SeismiKtron then counts time until it receives a signal from the Transmitter Unit. Once the signal is received, the entire instrument becomes disabled until it is again reset. This disabling action insures that the reading stays On and does not change.

The SeismiKtron provides two timing ranges. The First range allows a resolution of one tenth of one millisecond (0.0001 second). This range is particularly useful for short range exploration where a tenth of one millisecond may be as high as ten percent of the reading. The Second range increases the capability of the instrument tenfold. This range allows a maximum time interval reading of 999 milliseconds. Thus, it is like having two instruments in one.

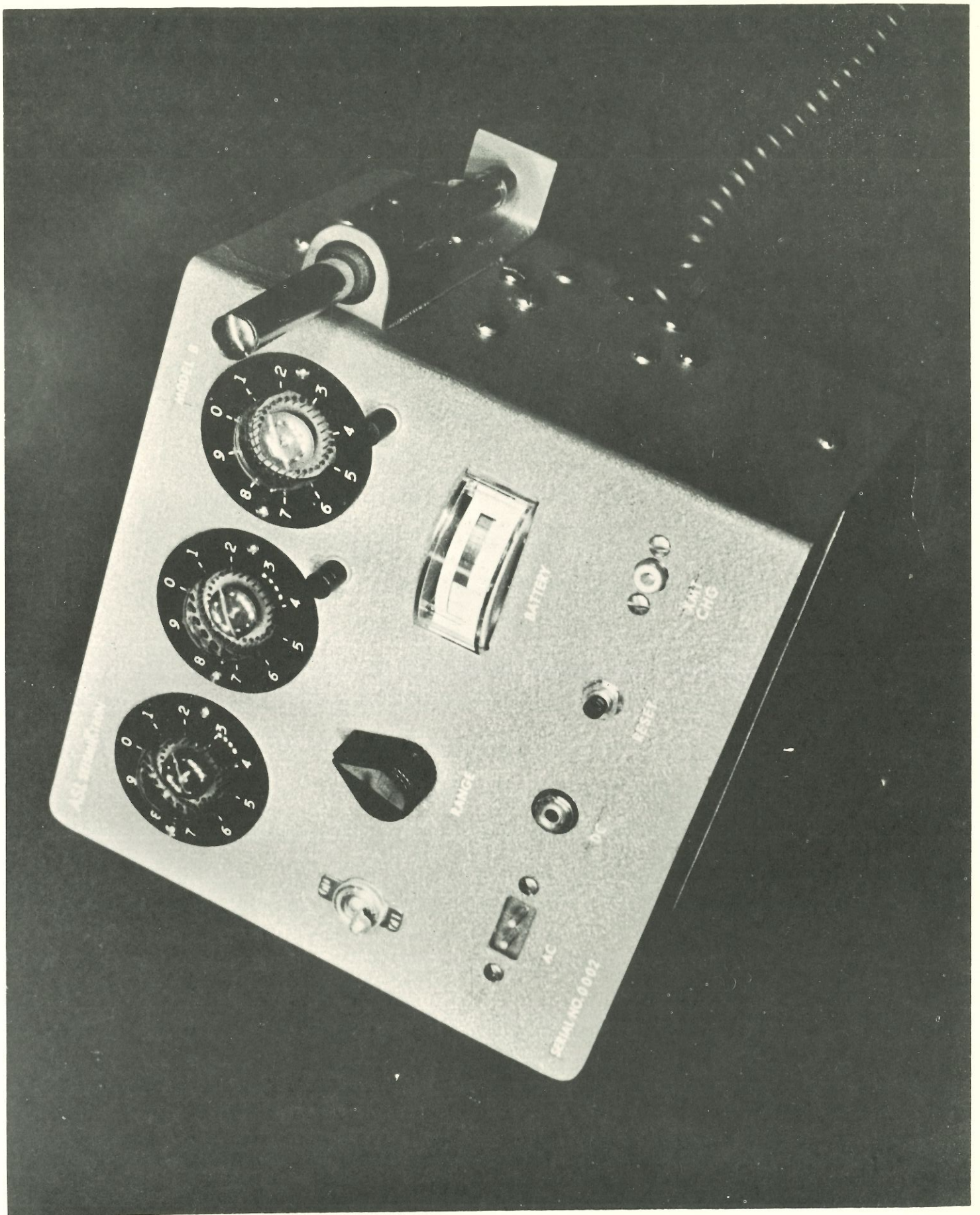

MAIN COUNTER UNIT

REMOVED FROM CARRYING CASE

F E A T U R E S

- * Small Size - 7 x 7 x 11 inches
- * Light Weight - 10 pounds
- * Direct Reading of Time Measurement
- * Rechargeable Batteries
- * Built-in Battery Charger - for both AC and DC
- * Built-in Charge Indicator
- * Two Timing Ranges - for greater accuracy
- * Radio Connection Between Units by Telemetry
- * Modern Transistor, Printed Circuit Design
- * Modular Plug-in Construction
- * One Full Year Factory Guarantee
- * Timing Resolution to 0.0001 second
- * Maximum Time Interval of 999 Milliseconds
- * No Tuning or Adjustments to Use
- * Automatic Sensitivity Controls
- * Complies with all applicable FCC requirements

A Product Of

ADVANCED SYSTEMS LABORATORIES, INC.
9 FAYETTE STREET
ROCKVILLE, MD.

TRACE RECORDER CONTROL TYPE *Case* 614



Weighs only 9½ lbs.
Supplies power to magnetometer from portable batteries.
Accuracy within 1%.
Can be used with internal recorder (type A) or large-span external recorder (type B)

Both analogue trace, digital or punch tape recording are possible. The trace method is the most usual application, but details of other methods can be sent on request.

A decision must be made as to which type of display is most suitable. This will depend largely on the power supplies available. We are able to supply two alternatives:

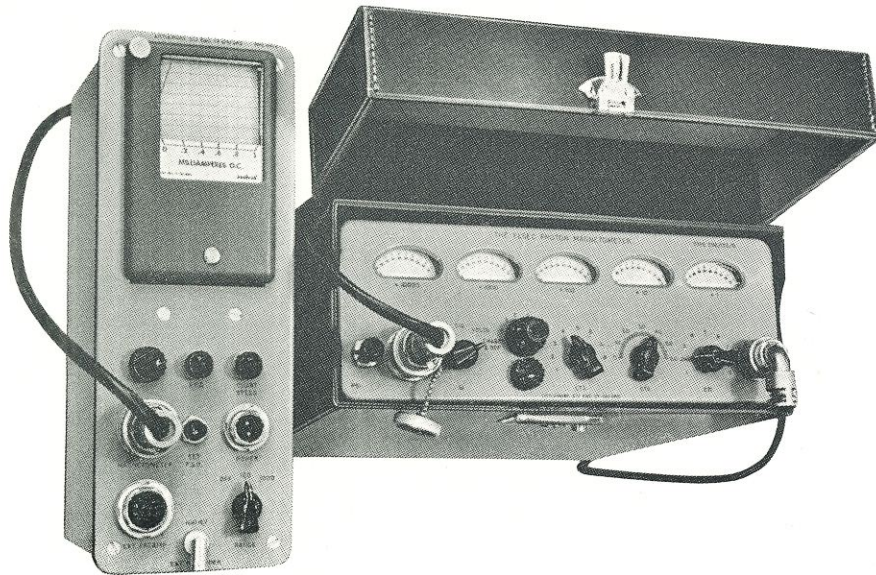

a The recorder control unit (Type 614A) can be supplied with a small D.C. operated trace recorder (Rustrak) fitted within the same case. This instrument (F.S.D.=1 ma) has a scale span of three inches only. If at any time it is considered that the accuracy of the Rustrak instrument is not sufficient, an external 100 mV or 1 mA (at a maximum internal resistance of 100 ohms) F.S.D. recorder may be used in conjunction with the control unit. Such external recorder instruments may be obtained by the customer or can be supplied by the Littlemore Scientific Engineering Company as an extra. Either 6" or 10" full scale deflection instruments are available. Operation using 115 or 230 volt A.C. power is normal, although 24 volt D.C. instruments are available at extra cost. The relevant dimensions and weights of these various components are as follows:

Unit	Dimensions	Weight
Type 614A Control	12½" x 4½" x 8" deep	9½ lbs.
10" Recorder	19½" x 18¼" x 15½" deep	115 lbs.
6" Recorder	10¾" x 10" x 10" deep	35 lbs.

b The recorder control unit (Type 614B) is supplied without an internal trace recorder and has similar dimensions to the type 614A given above. This instrument requires an external recorder having 100 mV or 1mA F.S.D. (at a maximum internal resistance of 100 ohms.). Such recorders may be obtained by the customer or may be supplied by the Littlemore Scientific Engineering Company as an extra. Details of two typical instruments are given above.

POWER REQUIREMENTS

Both control instruments require a 24 volt D.C. power supply at 3.5 amps. maximum. The type 614B will also require A.C. power or extra D.C. current for operation of the recorder itself.

SPECIAL DETECTOR AND CABLE ASSEMBLY FOR SEA-GOING, AERIAL OR VEHICLE-BORNE SURVEYS

We are able to supply a specially developed rubber encapsulated detector bottle with low microphonic cable for use from ship, aeroplane or moving vehicles. In the last case, a long (25 ft.) pole may be used to carry the detector remote from the stray magnetic fields of the vehicle. For aerial survey work cables of about 150 ft. are generally found convenient; whereas for sea-going surveys cables up to 1,000 ft. may be used. At sea the detectors can be used to depths of at least 200 ft. Suitable cable-handling apparatus should be provided by the customer. The dimensions of the detector itself are 15" long x 3½" diameter.

RECORDER CONTROL TYPE 614

SPECIFICATION

INDICATION: Internal 2½" scale span "Rustrak" galvanometer type. *Chart speed* is variable between 2 and 60 in./hour by changeable gear-boxes. 2, 4, 6, 12, 20, 24, 30 and 60 in./hour are available. Customers should state which gear-boxes are required. Chart rolls are 63 ft. long.

or (ii) External recorder (not supplied) having either 1 mA (100 ohm.) or 10 mV. F.S.D. socket in front panel provides connection.

TYPE 614B No internal recorder provided. Socket in front panel allows connection of external recorder having either 1 mA. (100 ohm.) or 10 mV. F.S.D.

RANGE: Full scale deflection caused by 100 or 1,000 magnetometer units (see type 592 leaflet) e.g. At a field strength of 50,000 gamma approximate F.S.D.'s of 25, 50, 100, 200, 250, 400, 500, 1,000, 2,000 and 4,000 gamma may be obtained.

CONTROLS: (a) Range/Off switch.
(b) Set chart speed-fine control
(c) Set F.S.D.

POWER SUPPLY: 20 to 26 volts D.C. at 3.5 amps. max. (including power for detector bottle polarisation). The 12 volt D.C. necessary for operation of the magnetometer itself is also derived from the Type 614 unit.

ACCURACY: Control unit $\pm 0.25\%$. Rustrak recorder indicating unit $\pm 1\%$. External recorders have accuracy better than 0.25%.

DIMENSIONS: 12" wide x 4¾" deep x 8¾" high.

WEIGHT: 9½ lbs.

OPERATING TEMP RANGE: -10°C. to +40°C.

FINISH: Top panel Light Grey anodised aluminium. Cover box Hammer Grey Stove enamel.

THE LITTLEMORE SCIENTIFIC ENGINEERING COMPANY

Railway Lane · Littlemore · Oxford · England Telephone & Cables: OXFORD 78563

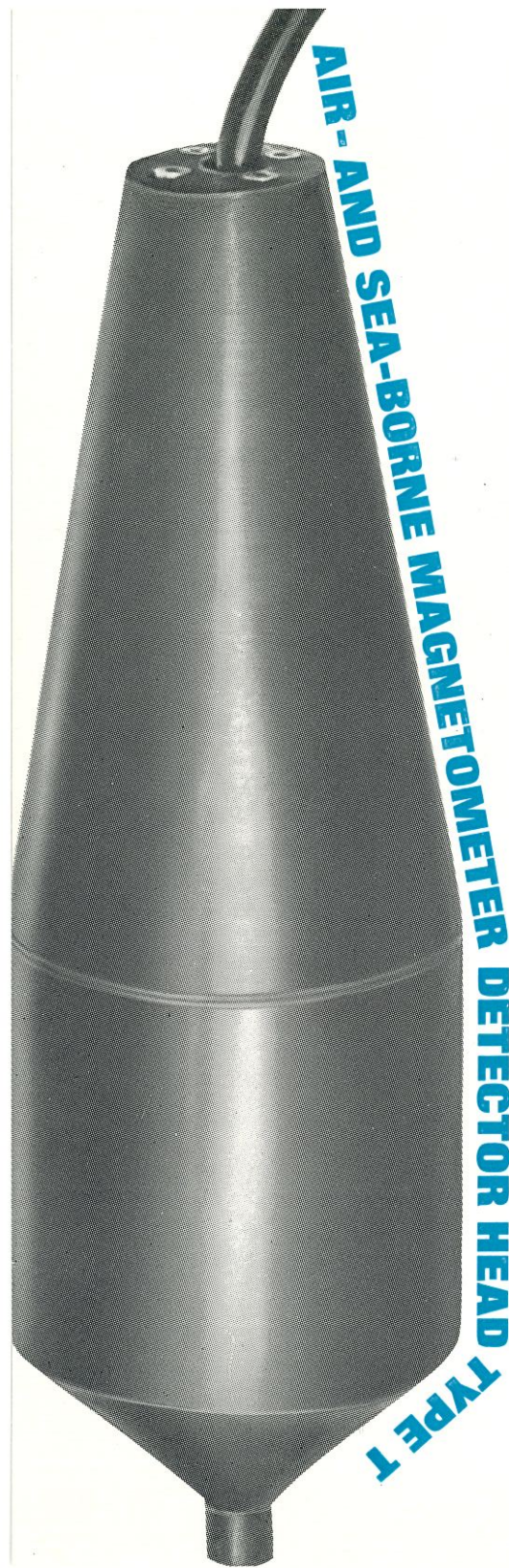

AIR- AND SEA-BORNE MAGNETOMETER DETECTOR HEAD TYPE T

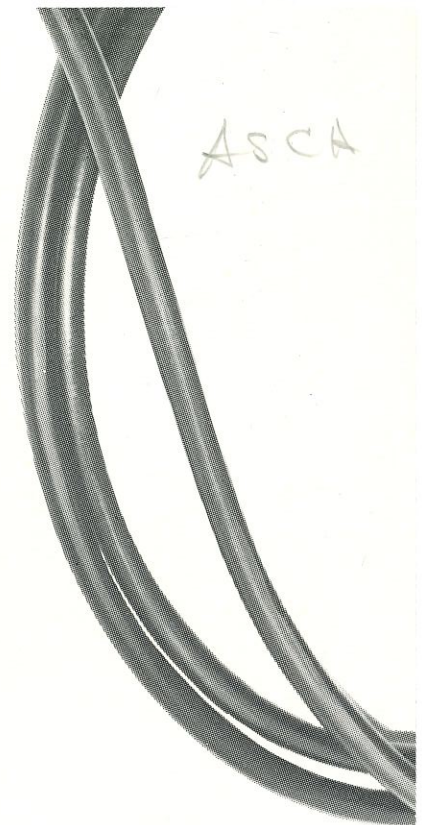

ASCA

* Can be used with all Type 592 Magnetometers. * Water-tight to 200 feet depth. (Greater depths on request) * Equally suitable for air and water surveys. * Towed by up to 1,000 feet of special non-microphonic cable. * Obviates necessity for external pre-amplifiers. * Special pliable encapsulation protects detector from damage. * Also suitable for land surveys where coaxial cable is moved.

The development of this magnetometer detector head is the result of considerable research due to difficulties experienced when making measurements with the detector to magnetometer measuring unit coaxial cable moving. Such movements of the cable result in spurious signals being superimposed on the proton signal with resulting inaccuracies of measurement.

The new cable (which is also available for use with existing detector heads) is non-microphonic and does not produce these spurious signals when vibrated. In the Type T detector head the cable is encapsulated into the cork and bottle assembly with suitable water-tight joints.

The detector may be filled with slow or fast decay liquids. The latter should only be used where repetition rates above 1 per 2 seconds are required.

Dimensions: Diameter $3\frac{3}{4}$ " Length 15" Weight: 7lbs.
Diameter of Towing Cable: 0.32" Weight of Towing Cable: 20lbs. per 100 metres.

THE LITTLEMORE SCIENTIFIC ENGINEERING CO.
RAILWAY LANE · LITTLEMORE · OXFORD · ENG.
Telephone & Cables: OXFORD 78563

ELSEC ^{TYPE 592} PROTON MAGNETOMETER



**MEASURES THE EARTH'S MAGNETIC FIELD
ACCURATELY NO LEVELLING, NO SETTING
UP. AS EASY TO USE AS A STOP WATCH.
LIGHT, PORTABLE, ROBUST. DIGITAL
INDICATION. RECORDING FACILITIES**

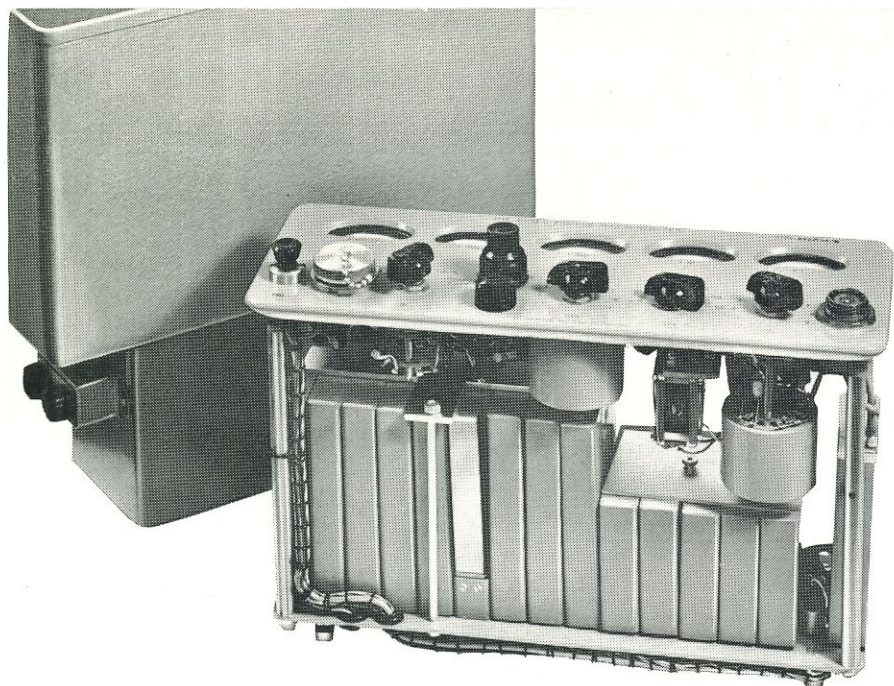

THE ELSEC PROTON MAGNETOMETER

**COMPLETELY ALTERS THE SCALE ON WHICH
MAGNETIC SURVEYING CAN BE ENVISAGED
AND CONSEQUENTLY MANY PREVIOUSLY UN-
EXPLORED AVENUES ARE NOW OPENED UP**

The Earth's magnetic field intensity can be evaluated by measurement of the proton free-precision frequency. The exploitation of this in the ELSEC Proton Magnetometer means that magnetic surveys can now be both accurate *and* rapid; thus the instrument is a key to vast amounts of new geological and geophysical data. Designed primarily as a portable self-contained unit for land surveys, if required it can be equipped with recording facilities for use at a base station and in ship or aeroplane. It is suitable also for the new archaeological technique of magnetic location of buried remains.

The ELSEC Proton Magnetometer measures the absolute magnitude of the earth's magnetic field intensity and it is ready to do this at any point of the earth's surface without internal adjustment. Its sensitivity is of the order of 1 gamma (0.00001 oersted) and its absolute calibration, being governed by a crystal-controlled oscillator, cannot drift.

There are no spirit levels . . . the detecting element is placed at the measuring station and connected by a light cable to the instrument itself. After switching on, the answer is displayed digitally on five meters. The meter divisions are large and no skill is necessary to read them. Closely spaced stations can be covered at the rate of 10 per minute. (N.B.—For aerial surveying a faster rate may be desirable and the overall measurement time can be reduced to 1 second if requested).

The instrument is designed for rough usage and is transistorized throughout. It is powered by miniature, non-spill accumulators of ample capacity for two days' field-work; these are easily rechargeable from a 12-volt car battery.

HOW TO MAKE

Place detector-bottle cable between bottle and 75 feet of Uniradio 70, used if required). Position from detector-bottle. For seconds, meter needle position remains until 'START' alternatively, the instrument automatically so that once the earth's field is accurate every few seconds. The leather carrying case th

THE DETECTOR

Fully protected with a resin. Permanently sealed to minus 70°C. by use of organic liquid. Mounted in aluminium prod; two supplied, 1 foot and 3 feet.

THE INSTRUMENT

Transistorized plug-in tuning controls are all require adjustment when field intensity there is a signal can be monitored switch. One of the field a test meter. Other power accumulator voltage, a decade meter 'nines'. Rated to ensure satisfactory background.

ACCUMULATORS

Transistorized stabilized digits. Carried in ea

SOME PRACTICAL DETAILS

ity can be evaluated by
ee-precision frequency.
LSEC Proton Magneto-
veys can now be both
rument is a key to vast
geophysical data. De-
-contained unit for land
quipped with recording
and in ship or aeroplane.
æological technique of
ins.

r measures the absolute
c field intensity and it is
earth's surface without
ty is of the order of 1
ts absolute calibration,
rolled oscillator, cannot

e detecting element is
nd connected by a light
fter switching on, the
ive meters. The meter
ecessary to read them.
vered at the rate of 10
eying a faster rate may
asurement time can be

gh usage and is trans-
ed by miniature, non-
ity for two days' field-
ble from a 12-volt car

HOW TO MAKE A MEASUREMENT

Place detector-bottle at measuring station. Connect cable between bottle and instrument (standard cable is 75 feet of Uniradio 70, longer or shorter lengths can be used if required). Position instrument more than 20 feet from detector-bottle. Press 'START' button. After a few seconds, meter needles indicate answer digitally. Indication remains until 'START' button is next pressed. Alternatively, the instrument can be set to recycle automatically so that once switched on the measurement of the earth's field is accomplished and shown on the meters every few seconds. The instrument stays in its stout leather carrying case throughout the measurement.

THE DETECTOR BOTTLE

Fully protected with a cylinder of casting resin. Permanently sealed. Operates down to *minus* 70°C. by use of specially selected organic liquid. Mounted on detachable aluminium prod; two standard lengths supplied, 1 foot and 3 feet.



THE INSTRUMENT

Transistorized plug-in units used throughout. Amplifier tuning controls are all external on front panel; these require adjustment when moving to a new locality if the field intensity there is different by more than 2%. Proton signal can be monitored on the test meter with selector switch. One of the field indicating meters may be used as a test meter. Other positions of selector switch show accumulator voltage, accumulator charging current and decade meter 'nines'. Special rejection filters incorporated to ensure satisfactory operation in high A.C. mains background.

ACCUMULATORS

Transistorized stabilizer ensures correctness of meter digits. Carried in easily changeable screw-on pack.

Other 12-volt D.C. sources can be plugged into the instrument if desired. Charging through front-panel plug *direct* from 12-volt car battery. Charging current monitored on the test meter. Accumulator capacity of 8 A.H. is ample for two days' normal field-work.

RECYCLING

A concentric switch in the front panel allows two adjustments:

1. The number of proton pulses counted may be varied. 256, 512, 1024, 2048 or 4096 pulses may be selected. By this means the accuracy of the measurement may be varied. A decision as to which position of the switch should be used will depend on such considerations as signal/noise ratio, repetition rate and accuracy required.

At a field strength of 0.5 oersted the ultimate accuracy of measurement may be varied from ± 4 gamma to ± 0.25 gamma.

2. The other section of the switch varies the recycling time of the instrument. The period of proton polarisation may be varied between $\frac{1}{2}$ sec. and 5 secs. while the read-out time is varied between $\frac{1}{2}$ sec. and infinity. Normally the instrument is despatched with the following polarisation and read-out times:

SWITCH POSITION	POLARISATION TIME—SECS.	READ-OUT TIME—SECS.	TOTAL RECYCLE TIME—SECS.
A	0.6	0.45	1.3
B	0.6	0.8	1.7
C	1.5	0.8	2.6
D	3.0	3.1	6.4
E	4.5	60.0	66.0
F	4.5	—	manual

Other combinations of timing can be arranged to special order.

SPECIAL

Digital and analogue recording facilities are available. Easily adaptable to high precision frequency and time interval measurements.

ELSEC TYPE 592 PROTON MAGNETOMETER

SPECIFICATION

Range:	24,000 to 70,000 gamma.
Sensitivity:	± 0.5 gamma, or better.
Absolute Calibration:	1 part in 50,000 over operating temperature range -10°C. to $+40^{\circ}\text{C.}$
Tolerable External Gradient:	200 gamma/metre for ± 0.5 gamma accuracy 400 gamma/metre for ± 1 gamma accuracy. 800 gamma/metre for ± 2 gamma accuracy.
Count Duration:	256, 512, 1024, 2048 or 4096 proton pulses, as selected by front panel switch.
Reading Repetition Rate:	Five automatic rates available between 1 per second and 1 per minute—selected by front panel switch. (For the fastest rate the sensitivity is ± 2 gamma). The instrument can also be switched to 'manual' in which case readings are initiated by push button.
Display:	On 5 meters graduated 0—9. (a) Push button to initiate reading. (b) Function/Test switch with 5 positions: 1. Off or Charge battery. 2. Measure battery voltage. 3. Measure amplitude of proton signal. 4. Normal operate position. 5. Set meters to '9'. (c) Coarse tuning switch. (d) Fine tuning condenser. (e) Auxiliary fine tuning switch. (f) Dual concentric switch: upper part controls Count Duration and lower part controls Reading Repetition rate.

Weight of Instrument	12 lbs.
Weight of Standard Battery Pack:	9 lbs.
Dimensions of Instrument without Batteries:	13" wide x $4\frac{1}{4}$ " deep x $8\frac{3}{4}$ " high.
Dimensions of Instrument with Standard Battery Pack in Carrying Case:	$13\frac{1}{2}$ " wide x $5\frac{1}{2}$ " deep x 14" high.
Finish:	Top panel Light Grey anodised aluminium. Cover box Hammer Grey stove enamel. All water-proofed and contained in a brown leather case with lock and key.
Operating Temperature Range:	-10°C. to $+40^{\circ}\text{C.}$ (+ 50°C. to special order).

DETECTOR BOTTLE (STANDARD)

Dimensions:	$5\frac{1}{2}$ " x $3\frac{1}{2}$ " diameter.
Weight:	$5\frac{1}{2}$ lbs.
Connected to Control Panel of Instrument by up to 200 feet of Coaxial Cable.	
Freezing Point of Detector Fluid:	-70°C.
<p>SPECIAL 'FAST' DETECTOR BOTTLE This is advised for repetition rates faster than one per two seconds, and is only supplied on special request. It can also be used for slower rates but the highest sensitivity is not then available. Dimensions, weight and cable details are as for the standard detector bottle.</p>	
Freezing Point of Detector Fluid:	-20°C.
Digital and analogue recording facilities are also available. Our technical staff are always available to discuss and advise on your problems	

The Littlemore Scientific Engineering Company, Railway Lane · Littlemore · Oxford · England. Telephone & Cables: Oxford 78563.

NOW:

MOBILE DRILLING'S NEW

All-Hydraulic **B-30** gives you an easy-to-operate rotary/auger rig with lightweight, go-anywhere versatility... plus big rig power at the drill spindle.

B-30

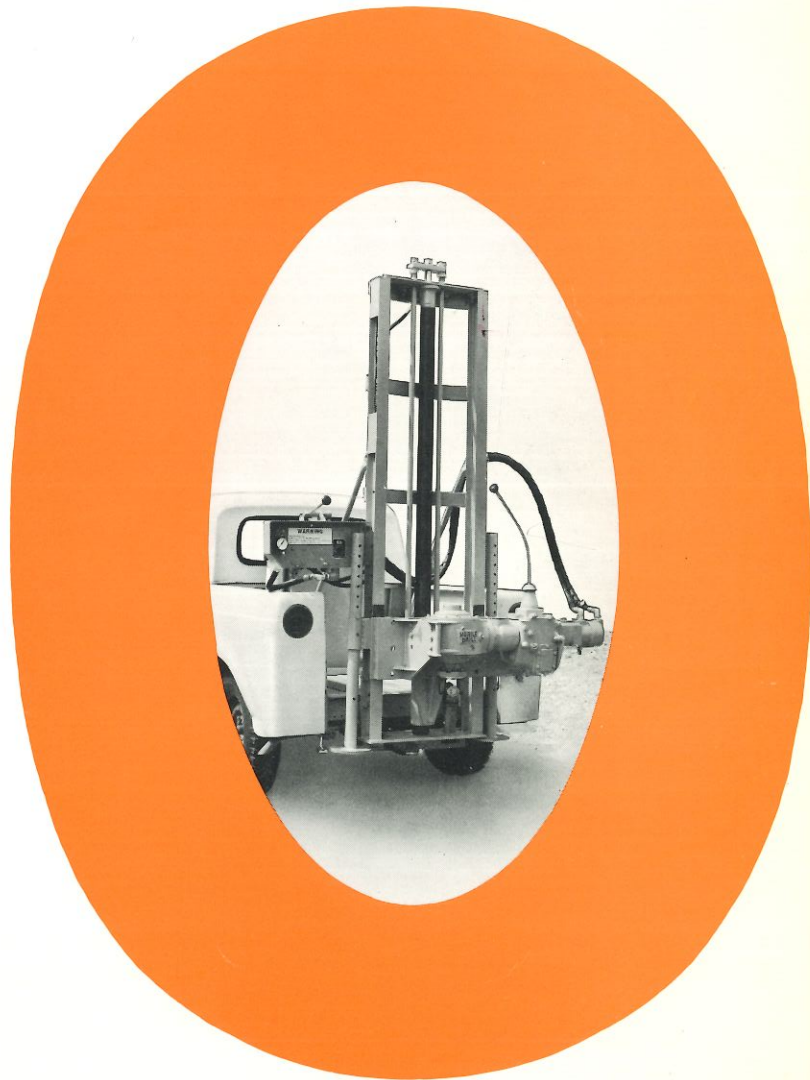

here's Mobile Drilling's new

B-30

...a rugged vertical auger drill that combines centralized controls with minimum maintenance hydraulic power to give you easy one-man operation...your best bet for profitable drilling.

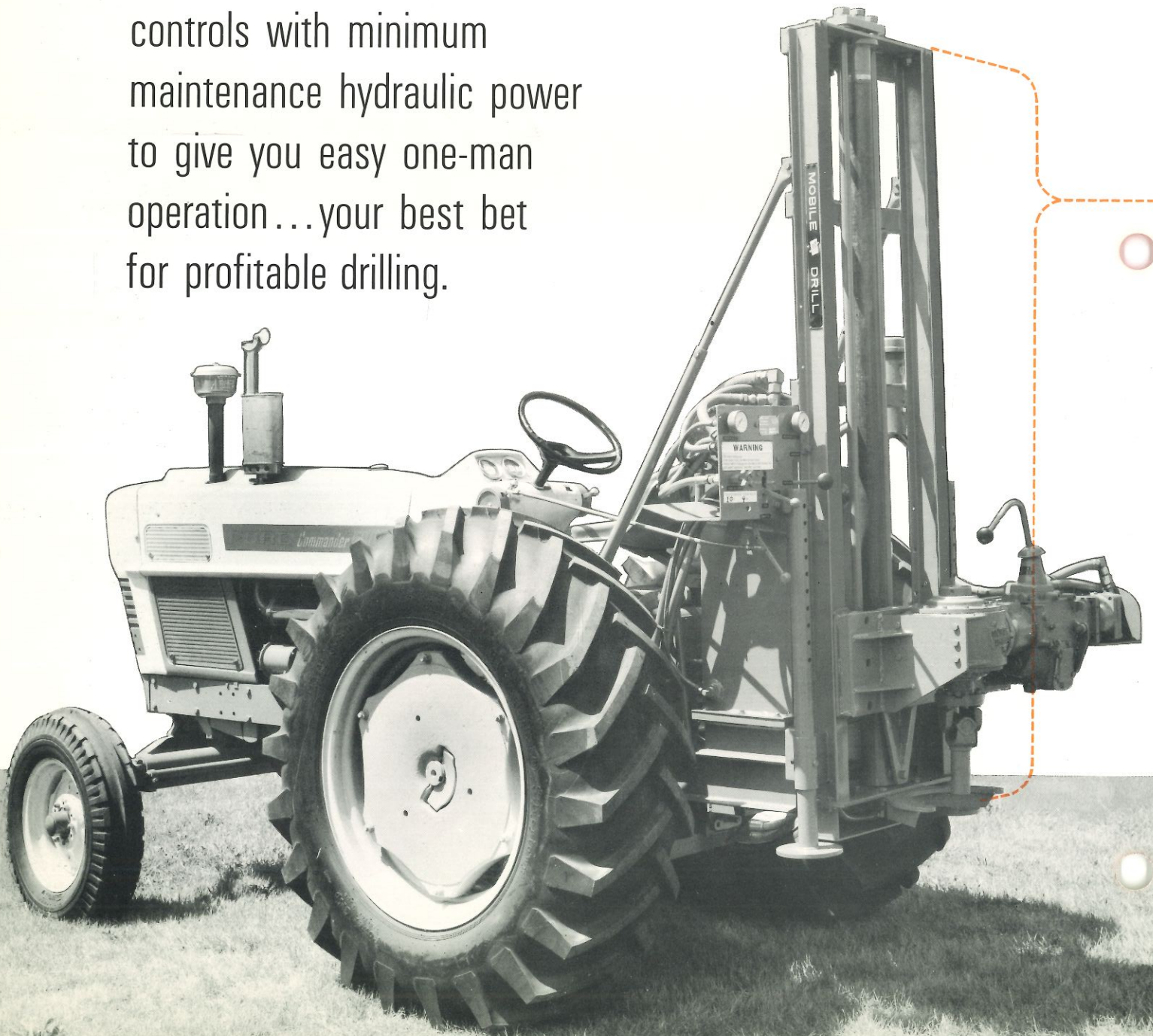

● GOES ANYWHERE

Through mud, snow, over rough terrain, the B-30 goes anywhere the vehicle itself can go. Drive directly to your job site, drill the hole or sample, and move on to your next location in minutes.

● SETS UP QUICKLY

Just position the vehicle, connect the first auger with cutter-head to the B-30's universal drive coupling and you're ready to go.

● TAKES ON A WIDE-RANGE OF DRILLING JOBS

Put the B-30 to work at mineral and aggregate prospecting, guard rail and post hole digging, sand drain boring, foundation exploration, soil sampling, seismic and cathodic work, shallow wells, pre-bid inspection and many other tasks.

● MOUNTS ON ANY ¾ TON VEHICLE

Steel frame construction is lightweight yet strong. Hydraulic drive mounts quickly and easily to the vehicle power take-off—truck or tractor—or can be furnished with independent gasoline engine for mounting on rear deck area of any 1 ton truck.

● ONE-MAN OPERATION

Operate the B-30 singlehanded. Simplified control panel at left rear of the vehicle adjusts to the operator's height regardless of mounting, making one-man operation safe and easy.

● FULL 68 INCH STROKE SPEEDS UP DRILLING

You drill a full 68" with one stroke before adding your next auger. Fast feed and retract speeds drilling progress. (See back page for FPM rate). Long stroke means fewer stops to add augers, more production time per hour.

● FULL RANGE AUGER DRILLING

Auger holes 24 inches in diameter to 5 feet, 12 inch holes to 30 feet, 6 inch holes to 75 feet, 4½ inch holes to 100 feet plus.

● PROTECTS ITSELF AGAINST OVERLOADS

The B-30's hydraulic safety bypass eliminates shear pins in the drive train and provides full-time overload protection when drilling in gravel or cohesive soils. Safety bypass automatically stops rotation when overload is encountered. Rotation automatically resumes as auger is retracted.

● OPERATES SAFELY AT FULL CAPACITY

The high torque cushioned performance of the B-30 hydraulic rotary head drive reduces vibration and shock loads. All steel frame takes day to day battering of rugged field drilling. Will not distort even under excessive loads.

● LOWERS MAINTENANCE COSTS

All-enclosed hydraulic drives reduce downtime and eliminate needless wear resulting from dirt and abrasion. Because the B-30 Mobile Drill® transmits its power hydraulically, no clutch or chain-drives are required and the possibility of internal malfunction is reduced to a minimum . . . a result of Mobile Drill® engineering which continues to set new high standards in the drilling industry.

CHECK THESE THREE IMPORTANT BENEFITS

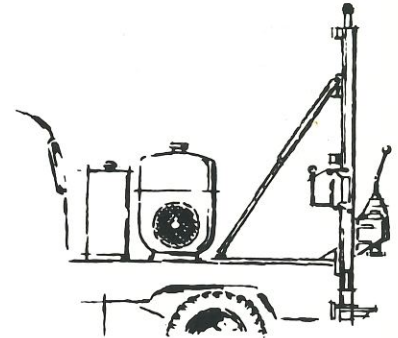

Engine Driven Model Available

Where PTO drive is not suitable, specify Mobile's optional independent engine drive. Mounted on the rear deck area of any 1 ton vehicle, standard engines available are 36 h.p. air cooled or 48 h.p. water cooled.

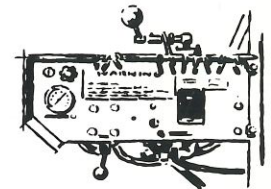

Adjustable Control Panel

Simplified control panel at left rear of vehicle contains controls for feed and rotation as well as an emergency power cut-off. A special rack at the top holds extra auger pins within easy reach of the operator. The entire control panel adjusts to the individual operator's height to insure safe, fast drilling. One man easily operates the B-30 Mobile Drill®.

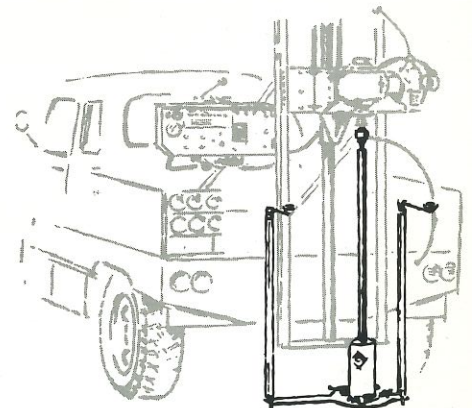

Conversion Kit for Concrete Coring

Available as an optional extra. Mobile Drilling's conversion kit quickly converts the B-30 for production test coring on highway pavement.

CHECK THESE RUGGED SPECIFICATIONS

...and you'll see why the B-30 gives you extra performance in an economical hydraulic drill.

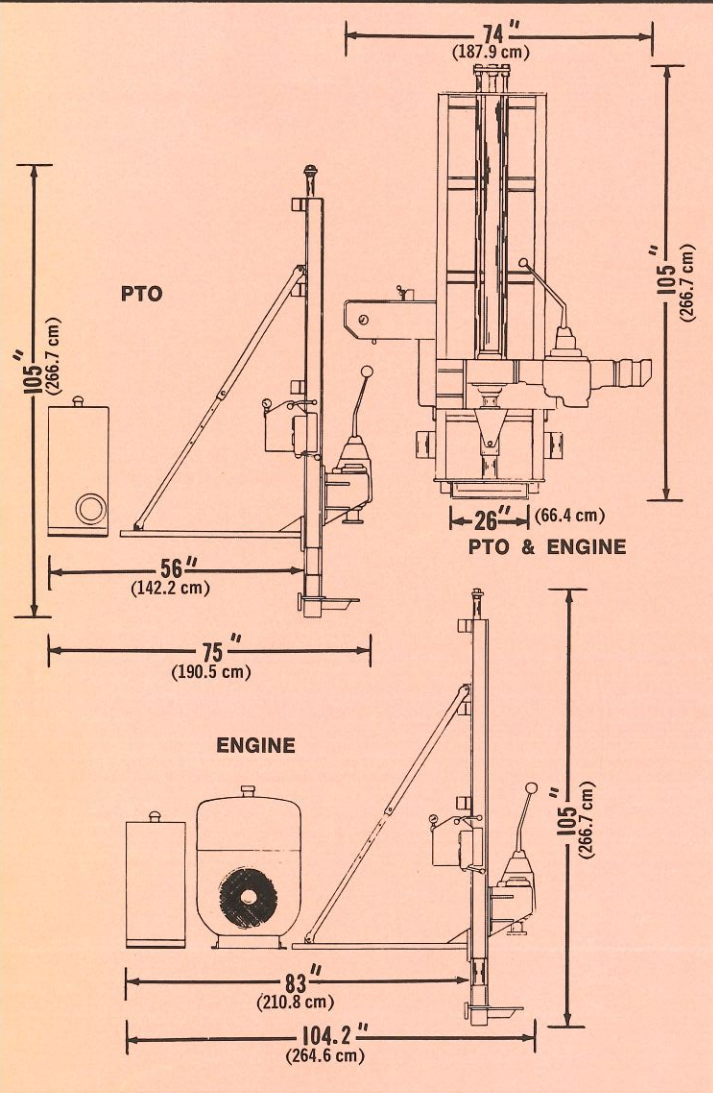

WEIGHT

Engine Driven

Net	with 36 H.P. Engine—1745 Lbs. (790 kg)
	with 48 H.P. Engine—1850 Lbs. (838 kg)
Export	with 36 H.P. Engine—2100 Lbs. (951 kg)
	with 48 H.P. Engine—2255 Lbs. (1008 kg)
	Cube with Either Engine 121 Cu. Ft. (3.39 cu. m.)

PTO Drive

Net	1289 Lbs. (584 kg)
Export	1540 Lbs. (698 kg)
	Cube..... 87 Cu. Ft. (2.44 cu. m.)

*STROKE 68" (173 cm)

FEED Hydraulic

RATE OF FREE FEED 58 FPM (29.4 cm/sec)

RATE OF RETRACT 103.9 FPM (53 cm/sec)

RAM PRESSURE

Up	8472 Lbs. (3838 kg)
Down	6362 Lbs. (2882 kg)

ENGINE (Standard)—Air Cooled—Wisc. VG4D 36 B.H.P.

(Standard)—Water Cooled—Ford JD172.... 48 B.H.P.

(Optional)—Diesel—Ford DD172 48 B.H.P.

DRILLING SPEED RANGE 58-455 RPM

ROTARY HEAD TORQUE AT

DRILL SPINDLE	Standard 2100 Ft. Lbs. (289.8 kg/m)
	Optional 3500 Ft. Lbs. (483 kg/m)
	Optional 5500 Ft. Lbs. (769 kg/m)

DRILL SPINDLE I.D. 2 $\frac{3}{4}$ " (6.985 cm)

DRILL CAPACITY

Auger Drilling Size Range (diameter)..... 2" thru 14" (5.08-35.5 cm)

Concrete Coring (diameter)..... 1" thru 12" (2.54-30.4 cm)

*Longer strokes available on special order

Dependable drilling equipment
made by a free people in the
United States of America.

27-Page Catalog No. 850

Lists more than 750 auger tools and accessories designed to help you speed up operations and reduce costs of auger exploration and production drilling. Send for your free copy today!



MOBILE DRILLING CO., INC.

3807 Madison Avenue • Indianapolis, Indiana 46227 • U.S.A.

AUGER DRILLING

Fast, profitable drilling of
large diameter holes in loose formations



E 66 11 P



What is auger drilling?

Basically, auger drilling is a mechanical method for the rapid and inexpensive boring of holes through earth layers and non-conglomerate formations. The drilling equipment consists of a drill head attached to an extendable auger shaft. A spiral flight runs the entire length of the auger shaft. This serves to remove the spoil. Drill tool guidance, rotation and feeding functions are incorporated in a drilling rig, which may be either stationary, vehicle-mounted or portable.

The advantages of auger drilling are many. The method is exceedingly fast. Large amounts of material can be brought to the surface within a short time. It is possible to drill holes with large diameters — in certain cases up to 1000 mm (42 in). The wall of the hole is stable, even in very loose material, and especially if there is water in the hole. The risk of cave-in is slight. Holes can be drilled at any angle to the surface.

In addition, compressed air and water supplies are not necessary for drilling.

The equipment runs without vibration and with little noise. Above all, it saves on both men and work-hours compared with other methods of doing the same work. The result is a very low cost per foot drilled.

There are two kinds of auger drilling — utility augering and continuous flight augering. The same rigs are employed for both but the drilling equipment differs.

Utility augering is intermittent. This means that the drilling tool is driven down a short distance and then lifted out and cleaned of earth. The procedure is repeated until the desired depth is reached.

This method is used for wide holes and shallow depths — usually diameters of 300–1000 mm (12 in–42 in) and depths down to 1.5 m (5 ft). Typical uses are the boring of holes for fences, poles, piles, plinths and foundations.

Continuous flight augering is employed for holes of smaller diameter and greater depth — diameters of approx. 50 to 300 mm (2 in to 12 in) and depths down to 100 m (300 ft). For this purpose the auger drills are manufactured in sections which are joined together until the desired depth is reached.

The spiral flight on the auger has a pitch so designed that the spoil is transported to the surface by rotation. The drilling tool need not be withdrawn until boring is completed.

Typical uses are boring for sub-surface investigation, prospecting and soil reinforcement, as well as certain types of well drilling and boring of blast holes.

Soil sampling is one of the main areas for the use of augering.

If disturbed samples are acceptable as, for example, when drilling in search of refractory clay, drilling is performed in the ordinary way with continuous flight augers. The material is brought to the surface by the drill rotation.

The depth to the find layer can be determined within approximately one metre (three feet) by calculating the length of the auger inside the hole. A more precise determination can be made by boring intermittently and pulling up each length of drill stem when it has been filled, but this is more time consuming and involves the risk of the hole caving in.

Hollow stem a disturbed samp has been develo ing Company, I

The convention tube with an ex centre drill rod end of the holl

During boring th together. When rod is withdraw latter replaced v again lowered in down to take th stationary. Fina withdrawn.

Hollow stem au mination. The si sample taking o **inside** the holl compact the fo typical.

In what can yo nonconglomer gravel (but seld of large, hard r clay and slate; many other mat obstacles.

For harder form from augering t

This medium-size (4½ in) angle ho Drilling rigs perm surface.



and shallow depths (12 in—42 in) and are the boring and foundations.

or holes of smaller diameters of approx. 50 to 100 m (300 ft). They are manufactured in lengths until the desired depth is reached.

which so designed augers can be rotated to surface by rotation. They are used until boring is completed.

face investigation, as well as certain types of holes.

as for the use of

as, for example, in clay, drilling is done with a continuous flight auger to the surface by the

determined within a few minutes by calculating the depth. A more precise depth is determined intermittently and when it has been reached and involves the

Hollow stem augers are employed when entirely undisturbed samples are desired. This type of drilling tool has been developed and introduced by the Mobile Drilling Company, Inc.

The conventional auger has been replaced by a heavy tube with an external flight. Inside the tube there is a centre drill rod. Drill heads are fastened to the lower end of the hollow stem auger and the centre rod.

During boring the hollow stem and centre rod are locked together. When a sample is to be taken the centre drill rod is withdrawn along with the cutting head and the latter replaced with a sampling device. The centre rod is again lowered into the hollow stem and rotated or pushed down to take the sample, while the hollow stem remains stationary. Finally, the centre rod and the sample are withdrawn.

Hollow stem augers eliminate the risk of sample contamination. The sides of the hole cannot cave-in during the sample taking due to the fact that the sample is lifted **inside** the hollow stem. Because augering does not compact the formation the density of the sample is also typical.

In what can you drill? Augering is best suited for most nonconglomerate formations, such as earth, sand and gravel (but seldom for boulder clay, where the presence of large, hard rocks makes the method impractical); for clay and slate; for chalk, limestone and coal; and for many other materials. Drilling in frozen soil presents no obstacles.

For harder formations most auger rigs allow transition from augering to rotary drilling with drag or roller bits.

This medium-size type B-40L auger rig is drilling 114 mm (4½ in) angle holes for ground investigation. Craelius-Mobile Drilling rigs permit holes to be drilled at any angle to the surface.



If rock is hit after having bored through loose formations, work can continue with diamond core drilling without any modification of the rig.

Where can you drill? As a rule, hilly or inaccessible terrain presents no obstacle to auger drilling. The equipment is often mounted on an off-the-road vehicle such as a jeep, tractor or truck or on a trailer for towing by such a vehicle. The drilling rig does not affect the freedom of action of the vehicle. Set-up is quick and simple. Drilling is not dependent upon the availability of water, compressed air or electric power.

Where terrain conditions are such that no vehicle can operate, light portable drilling rigs are used. These do not have the same capacity as the vehicle mounted types, but they allow all the advantages of auger drilling to be enjoyed and their ease of mobility makes them highly versatile.

A method with a future. As a method auger drilling is not new. It has long been used for soil sampling, but most often with manual power. Mechanical augering was introduced several decades ago. With the steady improvement of tools and machines, auger drilling has increasingly come into use. And the possibilities for use continue to expand.

For this reason the Atlas Copco Group, through its subsidiary Craelius, has entered the auger drilling field in collaboration with the American company Mobile Drilling Company, Inc. — one of the pioneers. Mobile Drilling has been responsible for many of the innovations which have made auger drilling today's most profitable method for drilling in loose formations.

Auger sections up to 6 m (20 ft) can be handled by this B-61 Pacemaker. It permits vertical drilling to a depth of max. 80 m (262 ft) with diameters of 114—152 mm (4½ in—6 in).

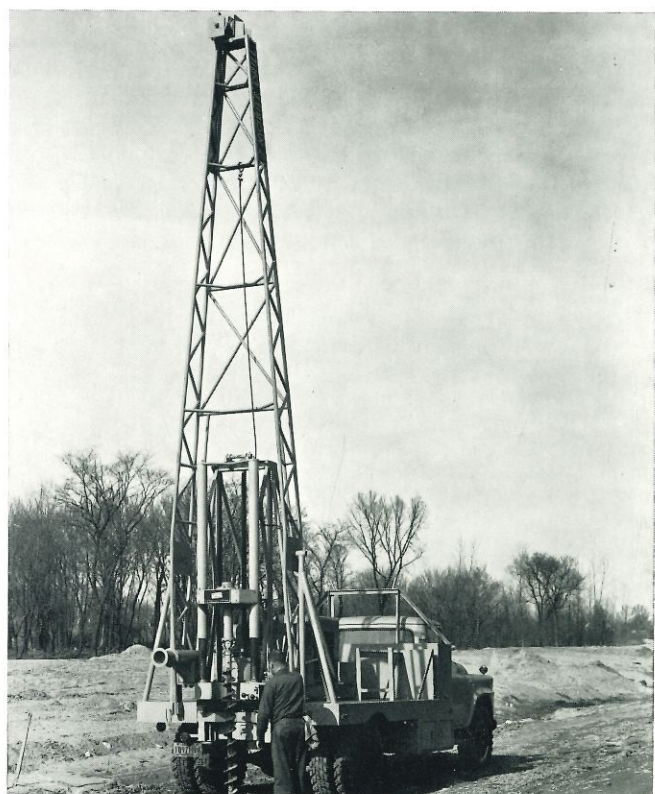

A complete range of rotary auger rigs

Craelius-Mobile Drill offer a choice of hydraulically powered auger rigs capable of drilling holes from 45 mm to 304 mm (2 1/2 in—12 in) down to depths of 100 metres (300 ft) in continuous flight augering and to depths of 1.5 metres (5 ft) with hole diameters up to 1067 mm (42 in) in utility augering. Most of these are multipurpose rigs, also usable for diamond core drilling and rotary boring. All rigs be used for soil sampling thanks to the Craelius-Mobile Drill hollowstem augers.

In order to obtain all the advantages offered by auger drilling it is essential to select a rig specifically constructed for auger drilling. Rigs built for diamond core drilling, for example, are not suited for auger drilling. They have too high a spindle rotation speed and too low a spindle output torque. In addition, feed length is usually too short. A drilling rig suitable for both continuous flight augering and utility augering should meet these specifications:

1. Rotation speed in lowest gear ratio should not exceed 50 rev/min.
2. Output torque should be ample even at highest rotation speed. High output torque is required especially for utility augering of large diameter holes.
3. Feed length should be at least as long as an auger section, in practice at least 1500 mm (59 in).
4. For effective operation in harder materials the drilling rig should provide high drilling pressure — up to 3 tons can be required in certain instances.
5. The drilling rig should be equipped with a safety device which stops rotation if the auger should stick.

Here is a short description of the major Craelius-Mobile Drill rigs. Complete descriptions and data for each individual type and of the other rigs available can be obtained from your nearest Craelius representative.

Light rigs for shallow holes

The Minuteman is a light petrol powered rig for vertical drilling. It weighs no more than approximately 100 kg (220 lb). The rig has rubber tyres for rapid transport between drill holes. Its low weight allows for permanent mounting even on the lightest types of vehicles.

The Minuteman is suitable for augers with diameters of 76–304 mm (3 in–12 in). Hole depth with a 76 mm (3 in) auger is approximately 15 m (50 ft). The power source is a 5 3/4 h.p. petrol engine. The gear box has three forward speeds and one reverse. A final drive offers two speed ranges. Feed length is 1.1 m (44 in). The machine can feed hydraulically or manually.



Multi-purpose truck-mounted rigs for medium depth holes

The B-27 is a light rig for vertical continuous flight augering as well as for utility augering of large-diameter holes and is especially suited for soil sampling and prospecting work. It weighs approximately 300 kg (660 lb), which permits it to be mounted on a jeep or any other lightweight vehicle. The rig can be easily dismounted, thus freeing the vehicle for other duties.

Suitable auger diameter for continuous flight augering is 76–152 mm (3 in–6 in). With a hole diameter of 76 mm (3 in), maximum hole depth is 20–25 m (65–82 ft). Rotation speed is 65–400 rev/min. Feed length 1.7 m (68 in). The B-27 is powered by the vehicle p.t.o. with hydraulic power transmission for both rotation and feed. The rig is also available with a separate engine for mounting on a trailer or lorry platform.



The B-30 is an all-hydraulic one-man manoeuvred rig for vertical continuous flight augering and utility augering of large-diameter holes. Suitable auger diameter is 44.5–304 mm (2 in–12 in) for continuous augering and 356–609 mm (14 in–24 in) for intermittent large diameter augering.

With a 152 mm (6 in) hole diameter, the maximum hole depth is 20–25 m (65–82 ft). Rotation speed is 58–455 rev/min. and feed length 1.7 m (68 in). The B 30 is vehicle p.t.o. driven, but is also available with a separate engine.



ed rigs

continuous flight
large-diameter
sampling and
300 kg (660
jeep or any
e easily dis-
duties.

at augering is
ter of 76 mm
n (65–82 ft).
n 1.7 m (68 in).
with hydraulic
feed. The rig
for mounting

The B-40 Explorer is an all-hydraulic medium-size rig for auger drilling at any angle to the surface. It can be mounted on a one-ton lorry. Fold-over mast and drill head assembly reduce travel clearance to mere inches above the lorry cab.

All normal diameters for continuous flight augering can be used. The rig is also suitable for utility augering of large diameter holes with auger diameters up to 609 mm (24 in). At a hole diameter of 114–152 mm (4 1/2 in–6 in), hole depth is maximum 30 m (100 ft) and feed length 1.7 m (68 in). Rotation speed is 58–455 rev/min.

The B-40 Explorer is normally self-contained, but is also available in a version for p.t.o drive.



The B-40 L is a medium-size rig for drilling at any angle to the surface. It allows for the use of extra long drill sections, thus shortening drilling time, even at greater depths, and minimizing manual handling. Three versions are available: for feed lengths of 3.7 m (12 ft), 5.2 m (17 ft) and 6.7 m (22 ft) respectively. The mast angle is hydraulically adjustable from 0°–90°.

All normal diameters for continuous auger drilling can be used. At 304 mm (12 in) hole diameter, maximum drilling depth is 30 m (100 ft). There are five gear ratios for rotation in either direction. The rotation speed range is 0–518 rev/min. The rig is available with either petrol or diesel engine.



Heavy-duty auger rigs for production-type drilling

B-52. Heavy-duty rig for vertical drilling, especially to greater depths.

Suitable auger diameter for continuous flight augering: 76–609 mm (3 in–24 in). Hole depths: at 152 mm (6 in) hole diameter approximately 60 m (200 ft); at 254 mm (10 in) hole diameter approximately 46 m (150 ft).

The B-52 is powered by a separate diesel or petrol engine. Accessories such as tower, cathead, water tank and pumps may easily be added.

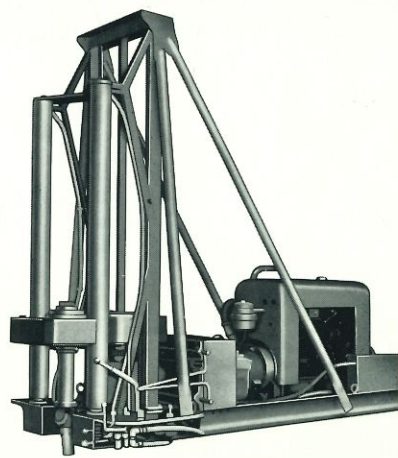

The B-61 Pacemaker is a rig for vertical drilling to greater depths and under difficult conditions. The fold-over mast can handle auger sections up to 6 m (20 ft) in length.

Suitable auger diameter for continuous flight augering is 76–304 mm (3 in–12 in). At diameters of 114–152 mm (4 1/2 in–6 in) hole depth is maximum 80 m (262 ft). Feed length is 1.7 m (68 in).

The B-61 Pacemaker is equipped with a 4-speed gearbox and torque converter. All gear ratios are available in both directions. Spindle speed range is 65–850 rev/min. The rig is powered by a separate petrol or diesel engine. A large selection of accessories for various applications is available.



A complete range of auger tools

Craelius-Mobile Drilling offer drill equipment for every conceivable type of auger drilling. The drill shanks, augers, bits, heads and accessories presented here constitute only a very small selection of what is available. Request complete technical information from your nearest Craelius representative.

Augers: For continuous flight augering, augers consist of sections which are joined together during operation until the desired length is reached. Section lengths from 0.9 m to 3 m (3 ft–10 ft) can be selected. Usually sections of 1.5 m or 3 m (5 ft or 10 ft) are employed.

Craelius-Mobile Drill augers have couplings of tubular profile with hexagonal sockets. Joining is accomplished by inserting a hexagonal union piece into the ends of both sections and locking it with a specially formed through-type U-pin. Joining can be carried out fairly quickly and torsionally the connection is extremely rigid, being unaffected by the direction of spindle rotation.

The Hex-Cor continuous flight auger has a high alloy seamless tubing shaft. Abrasion-resistant flights have a slightly tapered concave surface designed to throw spoil toward the shaft, minimizing clogging.

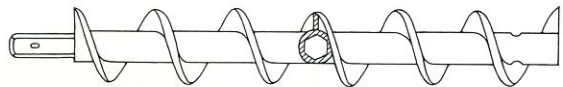

Rock Auger. For hole diameters from 355 mm to 863 mm (14 in to 34 in). Recommended for frozen sand, all types of stone, quartz, boulder-laden soils, stump removal.



Auger sections are also available for joining with A.P.I. threads or hex speed couplings. The use of these joining methods is limited to lighter drilling duties.

Augers are constructed of high tensile steel. The semi-concave flights are designed for maximum spoil conveyance with minimal clogging and flight drag. Flights are seam welded to tubular cores to ensure uniform pitch and greater strength.

Hard surfacing of flight edges substantially increases auger life. Craelius-Mobile Drill augers are available with a special chrome-manganese alloy built-up on the flight edges, which increases auger life approximately 50%.

Cutting tools. Normal drill heads have replaceable cutter bits fastened with wedges. Cutter bits of hardened steel are used for drilling in sand and gravel. For drilling in harder material, such as conglomerate and sedimented formations, cutter bits of sintered carbide are used.

Soil sampling using hollow-stem augers:
1. Auger flight and centre rod have reached the bottom of the hole. 2. Centre rod and drill head are withdrawn. 3. Sampling device is introduced through the hollow auger sections.

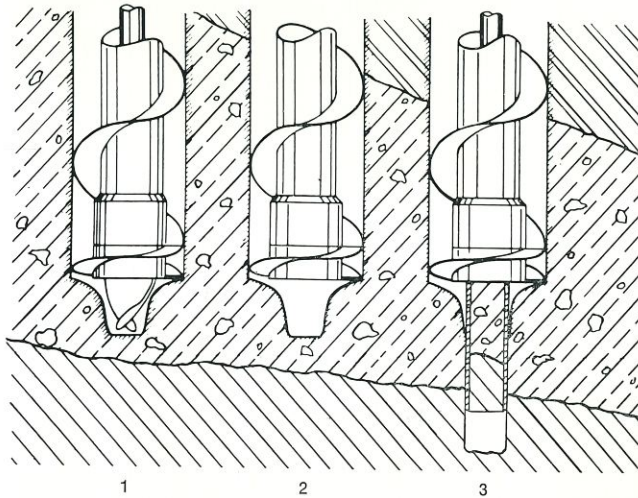

Short Shaft Auger. For hole diameters of 203 mm to 609 mm (8 in to 24 in). Designed for large-diameter boring in soft to medium soils.

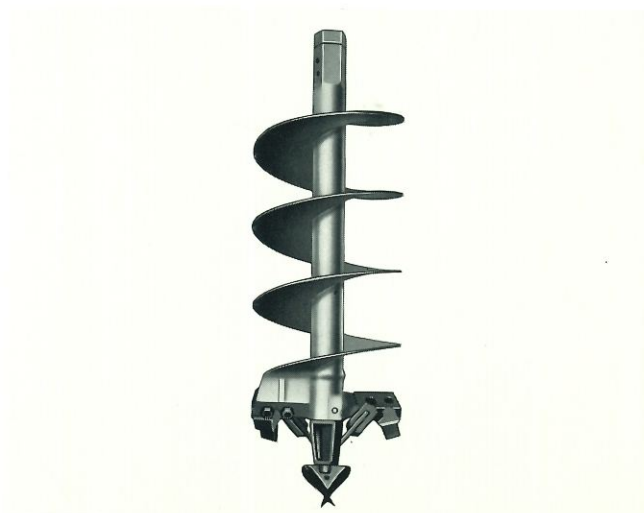

Fishtail-type such as cla a variety of

Selecting auger drilling work and conditions are g

1. Time er fore, alv
2. The dia ly 10% adequa
3. For hor should diamete

Earth Auger. D to 34 in). D consolidated gravel and s

Mining Bit. F 9 in). Recor

Fishtail-type drill heads are used for very soft materials, such as clay and soft marl. Cutting tools are available in a variety of types for drilling in different materials.

Selecting the right auger. For optimal exploitation of auger drilling, select equipment adapted to the type of work and conditions of soil. The following recommendations are generally applicable.

1. Time employed for coupling is non-productive. Therefore, always use the longest possible auger sections.
2. The diameter of the drill head should be approximately 10% greater than the auger diameter to ensure adequate "down the hole" clearance.
3. For horizontal drilling, the auger diameter and pitch should be the same. For example: 152 mm (6 in) diameter auger with 152 mm (6 in) flight pitch.

4. For vertical drilling the auger pitch should be only 69% to 80% of the auger diameter to ensure more effective spoil conveyance. Example: Auger diameter 152 mm (6 in) — flight pitch 102–127 mm (4 in–5 in).
5. U-pin auger connections are recommended for drilling in all formations and at any depth. They give maximum protection against accidental uncoupling.
6. Hex speed couplings should only be used for drilling in dry, relatively soft clays, shales and sandstones. The connection consists of a spring-loaded snap coupling. Hex speed assemblies are not recommended for drilling at greater depths and in hard and sticky formations as the couplings can loosen under these conditions.
7. A.P.I. threaded connections can be used in soft formations for both horizontal and vertical drilling or jetting. Threaded couplings are available in diameters up to and including 152 mm (6 in).

Earth Auger. For hole diameters from 304 mm to 863 mm (12 in to 34 in). Designed for boring large diameter holes in semi-consolidated clays, dense loams, marls, sandy clays where gravel and smaller size rocks may be present.

Clay Bit. For hole diameters from 64 mm to 254 mm (2 1/2 in to 10 in). Eliminates "dead spot" at hole center. Bores clean, straight holes through semi-consolidated clays, loams, soft shales and similar formations.

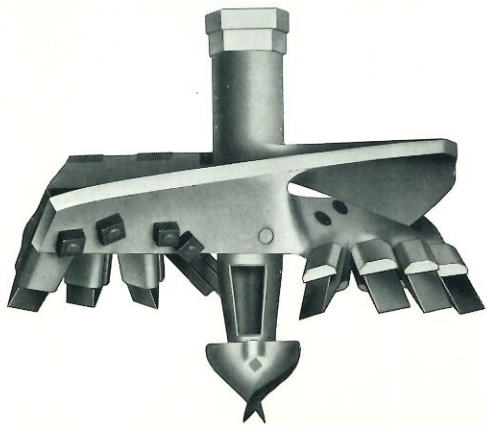

Mining Bit. For hole diameters from 76 mm to 229 mm (3 in to 9 in). Recommended for medium-hard, non-uniform material.



Rock Head. For hole diameters from 114 mm to 203 mm (4 1/2 in–8 in). Designed for use in the hardest formations. A whole range of finger-type drill heads are available for any type of formation.

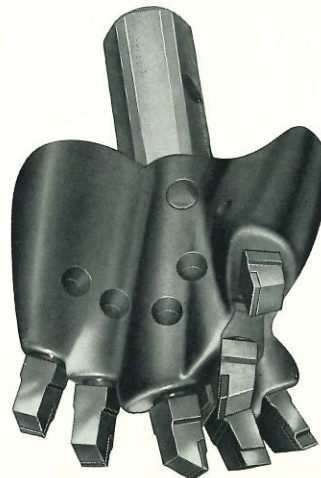
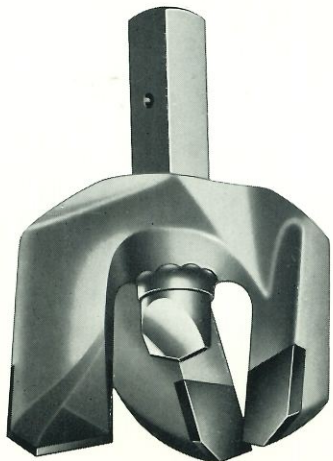

Craelius has the equipment you are looking for

Craelius has a complete range of equipment for auger drilling. You can obtain the equipment and accessories best suited to your special needs. Speak to your Craelius representative about your requirements and you will receive, without any obligation on your part, an exact and detailed proposal of equipment with all pertinent data.

It goes without saying that you want equipment and accessories that are dependable. The manufacturer is Mobile Drilling Company, Inc., USA, whose leading position in the field with 20 years of experience in auger drilling provides you with the best guarantee of dependability.

A world-wide organisation at your service. Craelius is part of the Atlas Copco Group. For more than a generation Craelius equipment has been in use throughout the world — rigs, diamond drills, pumps and measuring instruments. Europe, America, Asia, Africa: Craelius is there with storage and supply facilities, factories and technical service.

Atlas Copco is known the world over in the field of compressed air engineering: a well-known supplier of compressors, rock drills and other equipment for contracting work and mining. In addition, Atlas Copco offers a complete range of air-powered equipment for all other industrial fields.

Collaboration between Craelius and Atlas Copco is integrated and intensive; it includes research, development and manufacturing. Experience from all corners of the earth is collected and processed as the basis for fresh advances in the field of drilling techniques. You can quickly avail yourself of the latest developments through the Craelius/Atlas Copco sales organisation.



Mounted on a crawler chassis this B-40 auger rig performs penetration tests at bottom of a pre-augered vertical hole. This rig can drill holes at any angle to the surface to a depth of 30 m (90 ft) using 609 mm (24 in) augers.



Diamond core and auger drills and equipment, diamond products and instruments.

Fack Stockholm 1 · Sweden · Telegrams Adamante · Stockholm · Telex 14 59 · Telephone 98 05 20

Atlas Copco — Sales and service in more than 100 countries.

THE TWO WORLD WIDE DIAMOND CORE DRILLING STANDARDS

Craelius metric means greater choice
of core, hole, rod and casing sizes
... and cuts weights and drilling costs

American inch system (converted to
millimeters) as recommended by
Diamond Core Drill Manufacturers
Association of USA.

Casing OD/ID mm	Drill rod mm	Core ø mm	Hole ø mm	Hole ø mm	Core ø mm	Drill rod mm	Casing OD/ID mm
							239.0/203.0 8 in 39
							187.0/154.0 6 in 30
143/134 15.4	50 6.9	116	146				
128/119 13.8	50 6.9	101	131				129.0/102.0 4 in 16
113/104 12.4	50 6.9	86	116				
98/89 10.5	50 6.9	84	101				
84/77 7.2	42 4.4	72	86				88.9/76.2 NX 11.8
74/67 6.3	42 4.4	62	76				73.0/60.3 BX 9
64/57 5.2	42 4.4	52	66				
54/47 4.4	33 3.3	42	56				57.2/48.4 AX 4.5
44/37 3.5	33 3.3	32	46				46.0/38.1 EX 4.1
35/29 2.4	33 3.3	22	36				— EW 4.7

The red figures give the weight in kg/m

**Get down to it with
Craelius metric
for better drilling**



CASING TUBES			HOLE DIAMETER MM	CORE BARRELS		DRILL RODS		
Outer diam mm	Inner diam mm	Weight kg/m		Type	Core diam mm	Outer diam mm	Coupling inner diam mm	Weight kg/m
143	134	15.4	← 146 →	Z K-3	120 116	50	22	6.9
128	119	13.8	← 131 →	Z K-3	105 101	50	22	6.9
113	104	12.4	← 116 →	Z K-3	90 86	50	22	6.9
98	89	10.5	← 101 →	T Z K-3	84 75 72	50	22	6.9
				SK-4	70			
84	77	7.2	← 86 →	B T	72	42	22	4.4
				Z K-3	62 58			
				SK-4	58	82	68	9.5
74	67	6.3	← 76 →	B T	62	42	22	4.4
				Z K-3	54 48			
				SK-4	48	72	58	8.3
64	57	5.2	← 66 →	B T	52	42	22	4.4
				Z K-3	44 38			
				SK-4	40	63 ¹	49	7.2
54	47	4.4	← 56 →	B T	42	33	15	3.3
						42	22	4.4
				Z K-3	34 34	50	22	6.9
				SK-4	30	53 ¹	22	4.1
44	37	3.5	← 46 →	B T	32	33	15	3.3
						42	22	4.4
				Z K-3	28 24	43 ¹	22	2.5
				SK-4	20	43	30	4.3
35	29	2.4	← 36 →	B T	22	33	15	3.3
							33 ¹	15
			← 28 →	T	16	24	10	1.9

¹ Alurods ² Wireline

B, Z single tube
T, K-3 single and double tube
SK-4 Wireline